



Installation Instructions

TWSD16128PHC-UL





Introduction

The TWSD16128PHC-UL is intended to be used with UL listed WLAN / Networking devices both indoors and outdoors and to provide NEMA 3R protection with cooling and heating.

Maximum internal ambient temperature is 45 Degrees Celsius.

Before installing this product, read these instructions carefully. Failure to follow these instructions could lead to damage to the product or cause hazardous conditions.

Check the ratings on the products you intend to place inside the enclosure solution to ensure that they are suitable for the application.

Precautions

Read and understand all instructions before you begin installing the unit.

When installing and using this product, basic safety precautions should always be followed to reduce the risk of electric shock, fire and injury to persons.

All wiring that is connected to the equipment must meet applicable local and national building codes and network wiring standards for communications cable.

WARNING: To prevent the risk of electric shock and equipment damage, disconnect any and all supply mains connected to the enclosure before installing, maintaining or trouble shooting this product or any products inside the enclosure.

Keep these instructions for future reference.

Install only UL listed devices within the TWSD16128PHC-UL.

Follow all warnings and instructions marked on the product.

Insulation on all cables and wires installed by the service center must either be PVC, TFE, PTFE, FEP, Neoprene, or Polymide.

Never install cable, connectors or jacks in a wet location unless they are specifically designed for wet locations.

Never install this product during a lightning storm. There is a risk of electric shock from lightning.

Never touch uninsulated communication wires or terminals.

Disconnect power before cleaning or servicing the unit.

Version 1.1 - Page 2



Do not use liquid cleaners or aerosol cleaners. Use a damp cloth for cleaning.

Mount the unit according to these instructions only using the recommended or supplied hardware.

Wear proper eye protection when using power and hand tools. Follow all safety instructions provided with the tools.

This unit should only be connected to the type of power source indicated. If you are unsure of the type of power supply, consult the local power company.

WARNING: Do not overload outlets as this can result in a risk of fire or electrical shock.

Disconnect power should any of the following conditions occur:

- The TWSD16128PHC-UL does not operate normally when following the operating instructions;
- The TWSD16128PHC-UL has been damaged;
- The TWSD16128PHC-UL exhibits a distinct change in performance.

Heater / FAN

The TWSD16128PHC-UL includes a heating element as well as a cooling fan to provide protection to the internal components from extreme temperatures.

CAUTION: Never touch the moving parts of the fan while in operation. Never touch the heat sync of the heating element while in operation – the heat synch becomes very hot while in operation and could cause personal injury if touched.

Warning

WARNING: To prevent the risk of electric shock and equipment damage, disconnect any power supply to the enclosure before installing, maintaining or trouble shooting this product or any products inside the enclosure.



Installation Instructions

Installation Environment

The TWSD16128PHC-UL is intended for both indoor and outdoor use.

Maximum internal ambient is 45 Degrees Celsius.

Always mount the enclosure with the drain hole facing down (figure 1). Failure to do so could cause the unit to fill with water; creating hazardous conditions and equipment damage.

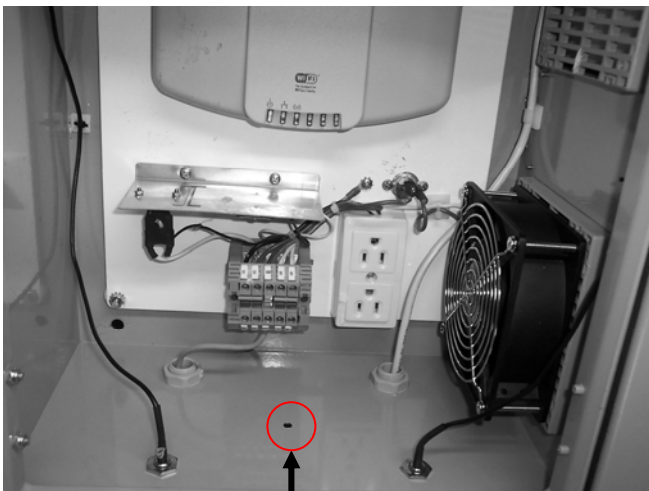

(Figure 1)

Drain Hole on Bottom of Enclosure

WARNING: To prevent the risk of electric shock and equipment damage, disconnect any and all power supplies to the enclosure before installing, maintaining or trouble shooting this product or any products inside the enclosure.

Included Components

The TWSD16128PHC-UL consists of the following components:



NEMA 4 Plug
Cooling Thermostat
Heating Thermostat
Heater
Cooling Fan



- Mounting plate
- Power socket
- Terminal Block
- Cord Gland
- Cable Tie Downs

Customers are required to install conduit for Ethernet. Conduit should be suitable for the application's environment and wet applications.

Customer Supplied Items

Customers are required to provide their own mounting hardware. TerraWave recommends 3/8 inch fasteners, washers, lock washers and nuts. See figure 2.

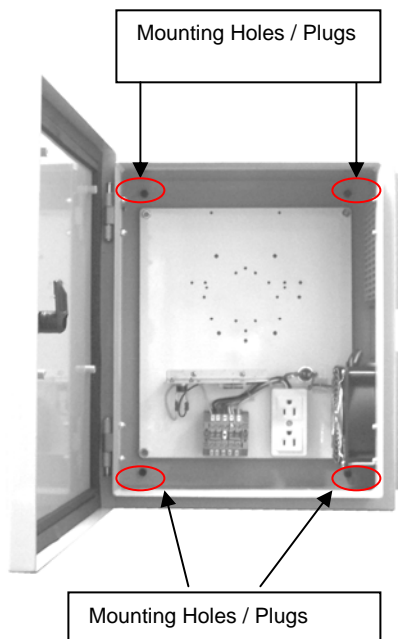

(Figure 2)

Drainage

The TWSD16128PHC-UL is supplied with a drain hole located on the bottom of the unit. The drain hole will allow any water build-up or condensation to drain from the unit. Never block the drainage hole. Refer to Figure 3 below.

CAUTION: To prevent the risk of electric shock, always mount the unit with the drain hole facing down and the unit level.

Do not mount anything to the bottom of the enclosure.

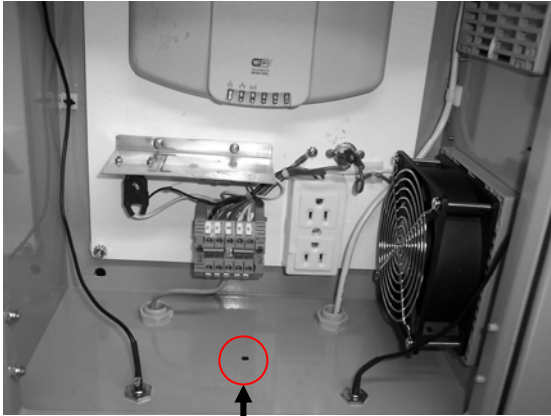

(Figure 3)

Drain hole on bottom of enclosure.
Do not mount anything on the bottom of the enclosure.

Installing WLAN / Networking Components

The TWSD16128PHC-UL will accommodate WLAN / Networking products to be installed inside the unit. This equipment should be installed on the mounting plate in the unit.

WARNING: Water or condensation may build up on the bottom of the enclosure. No equipment or live parts should be installed or placed on the bottom surface of the enclosure. Failure to do so could result in equipment damage.

Wire / Cable Routing

The TWSD16128PHC-UL comes with pre-installed cable routing tie downs. These tie downs are used to provide convenient cable routing. It is important to use these cable tie downs to ensure that the installed cables are kept away from the other components within the enclosure. Refer to figure 4 below to illustrate the use of these tie downs.

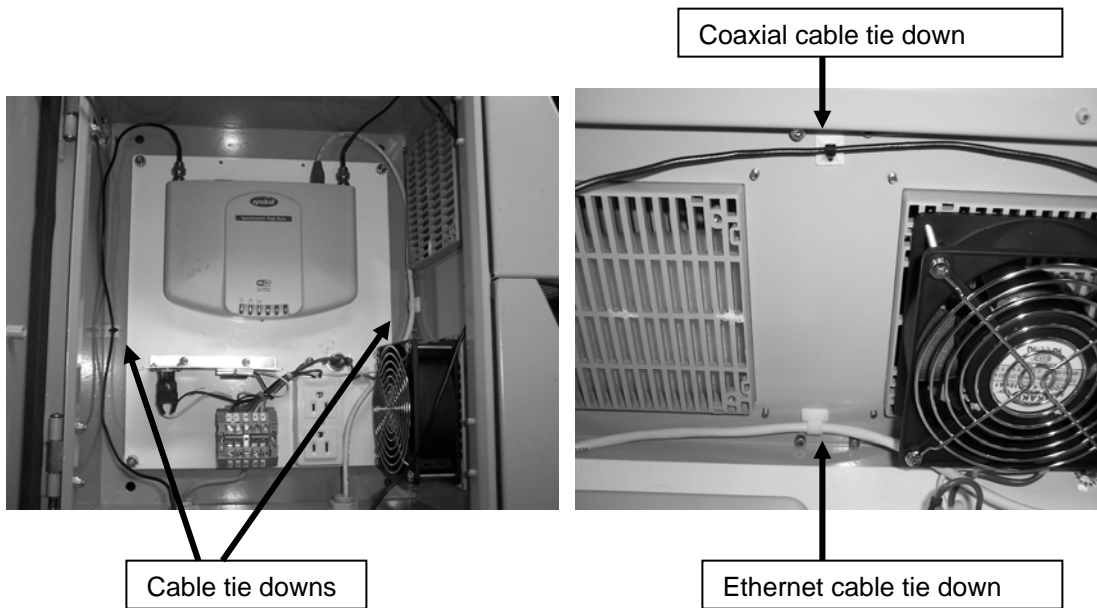

(Figure 4)

Ethernet Cable

When installing Ethernet cabling into the TWSD16128PHC-UL, you must remove the pre-installed NEMA 3R plug in the bottom of the enclosure. To remove the plug, simply loosen the fly nut located inside the unit. Once the fly nut has been removed, the plug will fall out of the enclosure. Replace the plug with conduit. The conduit must be suitable for environmental and wet locations. Refer to the NEC and follow any national or local codes. Refer to figure 5 below.

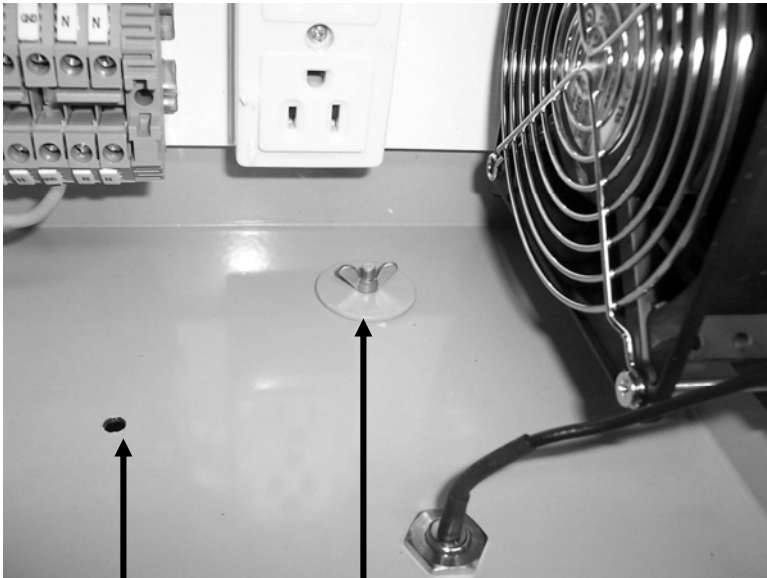

(Figure 5)

Drain Hole

NEMA 4 Plug with Fly Nut

Mounting Plate

The TWSD16128PHC-UL is supplied with a mounting plate to be used for attaching WLAN / Networking components. The following diagram (figure 6) shows which holes should be used when attaching approved products to the plate.

CAUTION: To reduce the risk of electric shock, do not drill any holes in the back plate.



Hole Size Chart

<u>Hole</u>		<u>Size & Thread</u>
A	=	7/32" through hole – not threaded
B, C, D, I, J	=	8-32 threaded hole
E, F, G	=	10-32 threaded hole
H	=	6-32 threaded hole

Hole usage ledger

<u>Hole</u>	<u>Used for</u>
A	Mounting holes to mate up with 10-32 thread x 2" standoffs
B	Cisco 350 Metal Case
C & F	Cisco 340 & 350 Plastic Case (F is for 10-32 locking post)
D	Cisco 1200 and 3Com 8250
I & E	Proxim AP (I is for 10-32 locking post)
J	Cisco 1130 AP
H & G	Symbol 4131 (G is for 10-32 locking post)

Customer Provided WLAN/Networking Mounting Screws

<u>Qty</u>	<u>Description</u>
4	10-32 x 3/8" counter sunk – Philips head
4	8-32 x 3/8" round Philips head
2	6-32 x 3/8" round Philips head
1	10-32 locking post (TerraWave has sample)
3	8-32 x 3/8" flat head Philips head

Enclosure Mounting Holes

Mounting holes have been provided in the back of the enclosure. These holes provide easy and convenient mounting of the unit.

Hole Plugs

The enclosure is supplied with pre-installed hole plugs which have been inserted into the mounting holes. These plugs need to be removed before mounting the unit. The plugs are easily removed by squeezing the lock clips on the inside of the unit. Once the lock clips of been pushed in, the hole plugs will easily slide out of the enclosure. Refer to figure 7.



Attachment

Attach the enclosure to a wall or other structure using the customer supplied 3/8 inch fasteners, flat washers and nuts. To ensure that the unit maintains proper sealing, it is very important to be sure that the fasteners, washer and nuts are tightened thoroughly.

Note: Loose fasteners, washers and nuts may not provide proper sealing and /or securing of the unit.

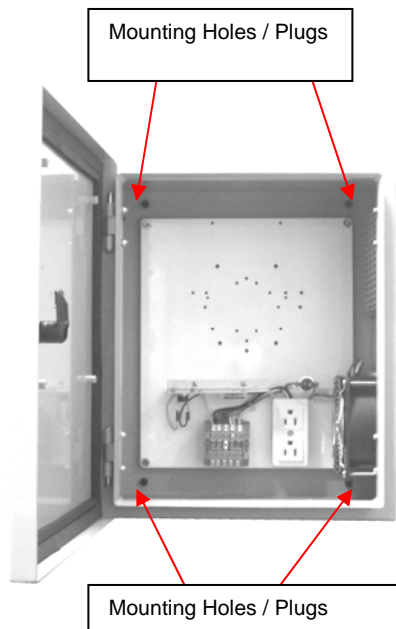

(Figure 7)

Electrical Wiring

NOTE

All electrical connections should be made by a licensed electrician. All local and National codes should be followed as applicable.

Circuit Requirements

The TWSD16128PHC-UL should be connected to a 120V, 15A feeder circuit. The maximum capacity of the power receptacle in the unit is 120V, 12A.

The circuit breaker of the feeder circuit is considered to be the disconnect device for TWSD16128PHC-UL. Therefore, this circuit breaker should be readily accessible.



The strain relief (liquid tight cord connector) is suitable for flexible cord with a diameter of 10mm. We recommend using S-W or S-J cord, minimum 16 AWG.

WARNING: TO REDUCE THE RISK OF ELECTRIC SHOCK, DISCONNECT SUPPLY MAINS BEFORE SERVICING.

The supply line used to feed power to the feeder circuit should be rated for outdoor use. Refer to the NEC and local codes as applicable.

WARNING: To prevent the risk of electric shock and equipment damage, disconnect any and all power supply to the enclosure before installing, maintaining or trouble shooting this product or any products inside the enclosure.

Electrical Connection

Before running electrical power to the device, you must first install the strain relief bushing that comes included with the enclosure. Be sure to install the strain relief bushing with the gasket of the outside of the enclosure. Also, the strain relief bushing nut should be tightened snugly by hand. Once the bushing has been tightened by hand, use a wrench to apply an additional quarter turn for final tightening. Do not over tighten the nut – over tightening the nut can cause the strain relief bushing to crack. Refer to figure 8.

The electrical wiring should be routed through the strain relief bushing to the terminal block. Refer to wiring diagram – figure 9.

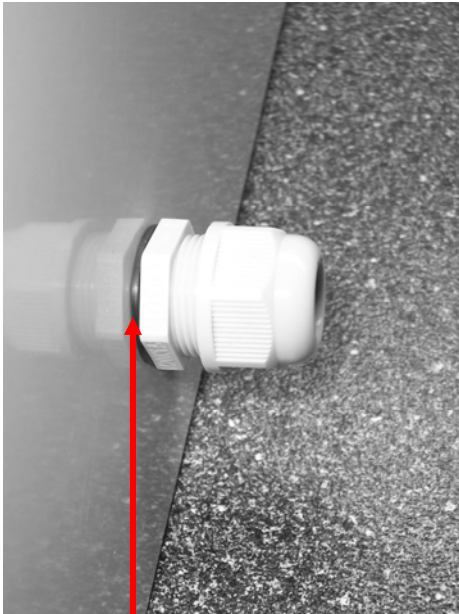

(Figure 8)

Strain relief bushing on outside of enclosure. When installing the strain relief, be sure that the gasket (black) is on the outside of the enclosure.

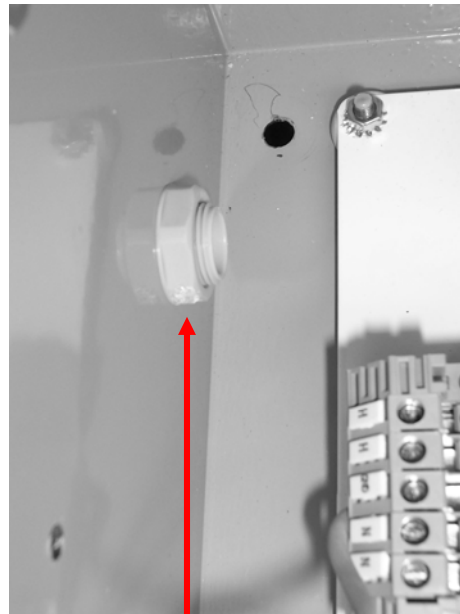

Strain relief bushing nut on inside of enclosure.

DO NOT OVER TIGHTEN!

Running Power to the Unit

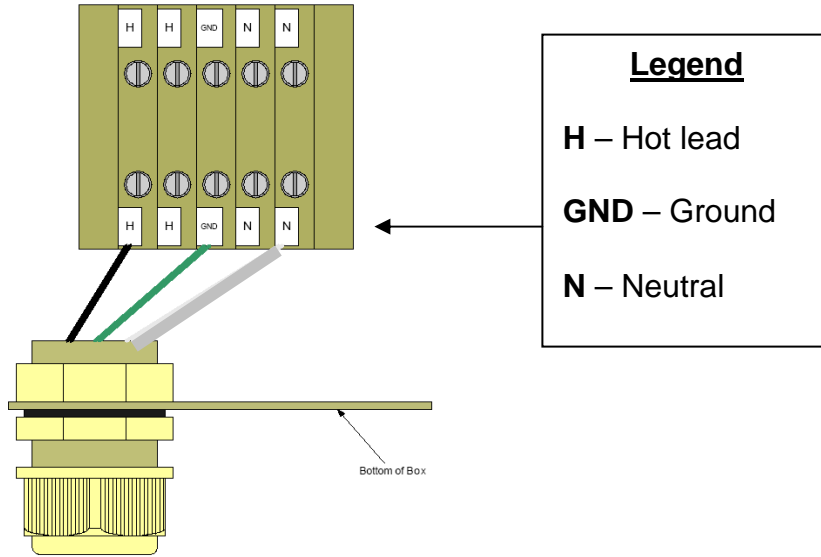

(Figure 9)

Note that all cables need to be rated for outdoor use and wet environments. Refer to the NEC and local codes as applicable.

Figure 5 represents the terminal block and power leads that are wired to the terminal block inside the TWSD16128PHC-UL.

The wiring should be applied as follows:

- 1.) The Black wire in figure 5 represents the hot lead and should be attached to the terminal block that is labeled 'H'.
- 2.) The Green wire in figure 5 represents the ground connection. The ground lead should be attached to the terminal block that is labeled 'GND'.
- 3.) The Gray wire in figure 5 represents the neutral. The neutral wire should be attached to the terminal block labeled 'N'.